



WITTENSTEIN

# move

The magazine of customers and friends of WITTENSTEIN AG

10 years of WITTENSTEIN AG – together into the future

7

October · 2011

## Masthead

**Publisher:**

WITTENSTEIN AG  
Walter-Wittenstein-Str. 1  
D-97999 Igersheim  
Phone: +49 7931 493-0  
www.wittenstein.de  
move@wittenstein.de

**Editorial content:**

Sabine Maier, Manager Public Relations & Media  
(Responsible under press law)  
(Marketing & Communications Dept.)

**Circulation:**

3.000 copies

**Production:**

WAJS  
Otto-Hahn-Str. 13  
D-97204 Höchberg

Title-page: The WITTENSTEIN AG production  
team in Igersheim-Harthausen

All rights reserved. This document may not be reprinted or  
electronically distributed without the express permission of  
the publisher.

## Contents

|  |    |
|--|----|
| <b>10 years of WITTENSTEIN AG</b>                    |    |
| Interview with Dr. Manfred Wittenstein _____         | 4  |
| <b>Mechatronic drive design</b>                      |    |
| WITTENSTEIN alpha GmbH _____                         | 6  |
| <b>Sensors with a “money back” guarantee</b>         |    |
| WITTENSTEIN AG Switzerland _____                     | 8  |
| <b>RPM+ motor-gearhead unit</b>                      |    |
| For innovative rack-and-pinion solutions _____       | 10 |
| <b>Back to the classroom – to help you learn!</b>    |    |
| Certified trainers train WITTENSTEIN customers _____ | 12 |
| <b>Italian projects meet German reliability</b>      |    |
| WITTENSTEIN Italy _____                              | 14 |
| <b>Haptic technology for flight training</b>         |    |
| WITTENSTEIN USA _____                                | 16 |
| <b>Power-IQ-Drives – compact and modular</b>         |    |
| WITTENSTEIN electronics GmbH _____                   | 18 |
| <b>Trade fairs</b> _____                             | 19 |

Dear readers,

Responsibility pays off. Now that the economy is booming again, the importance and necessity of developing a successful strategy for “life after the recession” is especially clear. As an export nation, Germany – and above all the capital goods sector – was particularly badly hit by the worldwide slump in demand. In spite of this, the German engineering industry continues to play an outstanding role in the international markets, helping to shape globalization and profiting from it more than most. At the same time, the challenges posed by the present upswing are universally valid: raw material shortages and material supply bottlenecks, leading to availability problems.

The recession has taught us that value creation must be founded not only on the past but also on the future. Success does not fall from the sky; it is the outcome of performance, excellence and reliability that have evolved over several decades – and of sustainable value development on the highest possible level. The WITTENSTEIN Group has risen to technology leadership in numerous disciplines of drive engineering and the intelligent solutions we offer our clients are aligned to the key challenges of the twenty-first century, for example in such fields as electromobility and resource efficiency.

As a trusted partner for industry we show our customers how innovative drive technology – in the form of products, systems and processes – can be continuously enhanced and optimized while reconciling economic with ecological requirements. This current issue of “move”, our customer magazine, describes a number of interesting examples. We regularly set benchmarks in linear drive technology. We are an active driver in the “StreetScooter” project – a joint initiative by RWTH Aachen University and automotive suppliers. A drivable prototype of this affordable electric car for urban transport was unveiled to a general audience at this year’s IAA exhibition in Frankfurt.

WITTENSTEIN, established in 1949, became a family owned, non-listed public limited company ten years ago this autumn. Since then, the world has moved on at a dramatic pace. One truth remains unchanged, however: inter-generational management, coupled with specialization on a very high level and a firm foundation of trust and dependability, invariably pays off. A company that makes efficient use of resources also works efficiently throughout. An employer that cares about and supports its staff and the society of which it is a part is rewarded with higher motivation, performance and acceptance.

Creating value is about recognition and respect. Our business success centres on people – the people who work for you, our customers, and us, the WITTENSTEIN Group. “Technology by people for people” – this is the underlying philosophy. You can make the acquaintance of a part of our team on the cover page.

I would like to end this editorial on a personal note: after 46 years at the company, I have made up my mind to retire at the end of the year. As a Management Board member with long-time responsibility for Finance and Human Resources, I know that competent and highly qualified staff are crucial to win your enthusiasm for our innovative products. Let us join hands to continue this successful partnership into the future!

The autumn season is also the season for trade fairs. Come along and visit us at the Stuttgart MOTEK and the Nuremberg SPS! We look forward to meeting you there!



A handwritten signature in black ink, appearing to read 'Klaus Spitzley'. The signature is fluid and cursive, with a long, sweeping underline that extends to the left.

Klaus Spitzley

WITTENSTEIN AG Management Board



*move* talks to:

# Dr. Manfred Wittenstein President, WITTENSTEIN AG

### 10 years of WITTENSTEIN AG

Exactly ten years ago, the WITTENSTEIN Group was given a new corporate structure – on September 13, 2001 it became a family owned, non-listed public limited company. A decade ago, WITTENSTEIN's total sales amounted to 148 million deutschmarks; in the meantime, they have risen to almost 200 million euros. The payroll, too, has easily doubled within the same period. *move* takes a look back – and a glimpse forward into the future – with Dr. Manfred Wittenstein:

***move:*** What were your reasons for changing the legal form and setting up the new company ten years ago, and what were your main objectives? With hindsight, was it a good decision?

**Dr. Manfred Wittenstein:** Without a doubt! The newly established WITTENSTEIN AG provided us with the necessary framework to steer our fast-growing company skilfully. The legal status of a public limited company forced us to optimize our internal workflows and helped us improve our international standing. Our customers have benefited from all of this in the long run. Our transition to an international business group has now been completed successfully. As a family owned enterprise, we consistently adopt a long-term perspective with sustainable value development as our goal, for which I bear direct responsibility.

***move:*** Looking back, what were the most important milestones over the last ten years?

**Dr. Manfred Wittenstein:** Continuous, systemic evolution has been our chosen strategy from the outset and that is how and we intend it to stay. WITTENSTEIN has successively extended its portfolio of services and solutions; all employees strive to uphold our commitment to being a world class global partner for the customers of our intelligent mechatronic drive technology, servo systems and components. One by one, we have set up independent subsidiaries around the world in order to offer our customers outstanding performance and expertise in all major technology and sales markets. On top of this, we have a majority share in attocube systems, the nano technology specialist based in Munich.

***move:*** Which issue currently takes priority for you?

**Dr. Manfred Wittenstein:** We place the present and future needs and wishes of our customers at the centre of everything we do. We invest enormous resources in the challenges confronting us. Despite the adverse conditions prevailing in 2009/10, the year of the recession, we avoided making any of our staff redundant; on the contrary, we expanded to new locations and built new manufacturing plants. By making our processes more secure, we are also in a position to serve our customers faster. The next step



Dr. Manfred Wittenstein  
President, WITTENSTEIN AG

in this direction will take place very soon: at the end of the year, WITTENSTEIN bastian will move into a new, 4000 square meter production facility in Fellbach. What makes this project unique is the ingenious overall concept, integrating the process, building and power supply components, which will enable us to operate with a zero carbon footprint – in Fellbach town centre. And in 2012, our company headquarters in Igersheim-Harthausen will be enlarged once again, with energy efficiency a primary planning criterion. These projects are just two examples of our willingness not only to take on business challenges but also to tackle the social issues of today.

**move:** When you look to the future, what do you see?

**Dr. Manfred Wittenstein:** I'm afraid I haven't got a crystal ball to help me answer that question. Nevertheless, I firmly believe that the current crisis can teach us some amazing lessons about shaping the future successfully. It's a well-known fact that a crisis is a time for developing new ideas, new concepts and eventually new technologies. The yearning for technological progress is as old as mankind itself; mega trends like mobility, the efficient use of resources and the insatiable thirst for participation and prosperity of many millions of people in the world's emerging economies underlie the social necessity for global changes. The contribution we make here is both our *raison d'être*

and a golden opportunity: in future, our ability to design highly complex systems that are capable of intelligent interaction will be a crucial aspect. We are dedicated to maintaining the success of our customers and to making sure they always stay one step ahead of the competition – hand in hand with us.

**move:** You once said in an interview that “future is change” and that you “want to be a part of it”. Where do you see WITTENSTEIN AG ten years from now in 2021?

**Dr. Manfred Wittenstein:** As I see it, there is no question that WITTENSTEIN AG will continue to grow worldwide. Our strategies, our know-how and our convictions are consistently aligned to the present and future needs of present and future customers; ultimately, they are driven by the great macro-economic and social challenges of our age. The future success and future growth of the WITTENSTEIN Group is not simply a personal goal of mine; above all, it will be the logical outcome of respectful and sustainable value development. The market – the customers whose enthusiasm we excite and win – is our motivation and our reward in one. That's how it is today and that's how it will be ten years from now!

# Mechatronic drive design: Our strategy for a strong head start



By  
Jürgen Guckenberger, application  
engineer and expert for drive sizing at  
WITTENSTEIN alpha

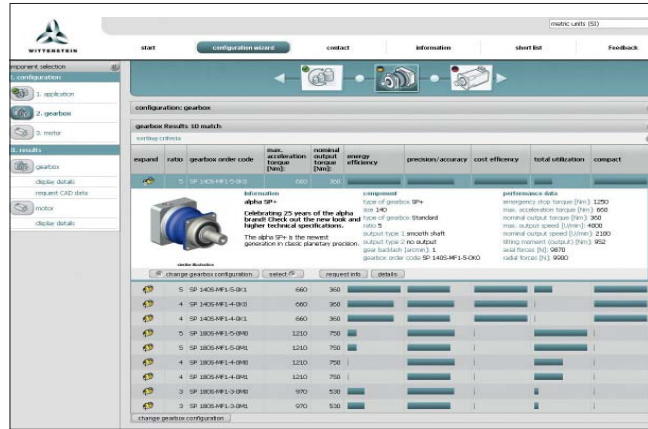

Sizing tool for WITTENSTEIN gearheads with fast access to technical specifications, 3D models and drawings

“Catalogue knowledge” alone results in suboptimal solutions when designing mechatronic drive systems. Enormous potential for optimization from the mechatronic perspective can often also be tapped in the application itself. The WITTENSTEIN strategy helps customers realize their objectives faster and more efficiently – and it also “pays” in the truest sense of the word. “Optimizing the task first, then the solution” is the name of the game. This strategy sets WITTENSTEIN clearly apart from its competitors – because it adds technical and commercial value for customers and conserves resources. Extended design and application areas as well as potentials for energy efficiency and downsizing powertrains are tapped in this manner – supported by new online configurators and the “Energie-Assistent” software tool, which is available in this form for the first time.

### Intelligent optimization of profiles

In the first step, the drive is not actually designed at all; instead, the central focus is the analysis and optimization of loads and motions. cymex® 3, our sizing software tool, makes a vital contribution. A thorough analysis of the positioning task and the associated motion and load profiles is performed after recording the fundamental framework conditions of the application, e.g. cycle or continuous operation, axial and radial forces, type of motion, permissible torsional backlash or minimum and maximum speeds. Depending on the profile, the torque actually occurring at the gearhead may substantially exceed the analytically calculated torque in dynamic applications – especially during acceleration and braking. In this case, overshoots of thirty or forty percent are likely in the drive system. After optimization with cymex® 3, the customer can utilize a so-called shock factor to estimate these effects. This factor helps size gearheads in such a way that they are capable of withstanding these peak loads. However, sizing “on the safe side”, in other words allowing power reserves, conflicts with the goal of miniaturization that is specified for almost every drive solution. The drives only get smaller if the

actual loads also get smaller thanks to an optimized motion. In order to optimize this “how” aspect of the motion, cymex® 3 optimizes the motion design by modelling application-specific motion ideals. These are characterized by acceleration and braking profiles limited by load peaks. The actual torques and the actual motion profile are then much closer to the analytically calculated values, so that overshoots in the drive system are reduced to a minimum. In the ideal scenario, the shock factor can be completely dispensed with, in which case the mechanical components can be designed thirty to forty percent smaller. The loads and size are not simply reduced, however – at the same time, the quality of the motion is improved because excitation of unwanted vibrations is avoided. The noise level is consequently lower and the drive runs smoothly and more or less vibration-free, which is a great advantage for the machine as a whole. By eliminating high load assumptions and safety margins in the form of regulation reserves and shock factors, it is possible to select smaller sizes and design drive systems that are far more energy efficient.



WITTENSTEIN alpha's new High Performance Linear System for highly complex linear movements

### Input power exceeding the catalogue values

Following the optimization of loads and motions, cymex® 3 identifies suitable gearheads and motors. Mass inertias are considered and gearhead properties defined, e.g. gearhead type, shaft design, type of construction or output geometry. The examination of lateral forces, inertia, speeds, torques and thermal criteria is the primary focus as the gearhead selection progresses further. cymex® 3 integrates these properties in the gearhead design and shows under which conditions higher speeds and/or radial forces or higher output torques exceeding the operating points, as defined by the technical specifications, can be realized with a particular gearhead. This results in extended design areas, i.e. additional usage potentials of the gearhead which can be safely and simultaneously controlled: more torque at reduced speed or more speed at reduced output torque. If this “intelligent” gearhead design is compared to the selection of a gearhead based on static catalogue data, additional possibilities for downsizing the power, product size and energy consumption of a mechatronic drive design beyond the initial load optimization become apparent.

### Recovering energy cuts costs and CO<sub>2</sub> emissions

Energy efficiency represents one of the biggest potentials for innovation in electric drive technology; as much as 30% energy can be economized in the mechanical portion of a powertrain. The chances of success are high if the energy that is utilized to accelerate and brake the drive's inertia no longer needs to be completely burnt up during braking – resulting in

wasted heat and lost energy – but can for the most part be recovered and “reused”. It was for precisely this reason that cymex® 3 has been enhanced with the “Energie-Assistent”. The only one of its kind in the market so far, this tool calculates a powertrain's energy consumption dynamically to permit a more energy efficient design. Customers can now see at a glance exactly how energy recovery technology will benefit their particular drive. The annual energy saving can be visualized in hard currency. Optimizing the task first, then the solution – this strategy for designing mechatronic drive systems delivers solutions that “pay” – from both a technical and a commercial point of view.

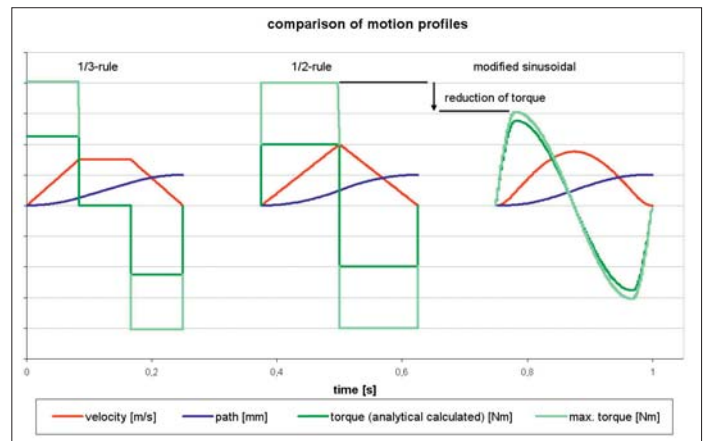

Analytical comparison of different motion profiles, each with 100 mm travel in 0.25 seconds

## Sensors with a „money back“ guarantee – Using torqXis to monitor drives is a worthwhile investment



By Stefan Basig  
Product Manager Sensors at  
WITTENSTEIN AG Switzerland



The torqXis SFR sensor measures torque, lateral forces and temperature simultaneously, directly in the drive train

**Machine downtime – especially if it is unscheduled – is usually far more expensive than the repair itself. Whereas the use of sensors to control and monitor industrial or logistical processes is nowadays taken for granted, it remains the exception when it comes to drive trains – a situation that is likely to change in the not-too-distant future. The immense interest in WITTENSTEIN’s modular torqXis sensor system suggests that a new trend is on the way.**

### **The drive’s “well-being” is paramount**

For customers of WITTENSTEIN, the efficiency of their machinery and plant is vital. Efficiency means a high power yield, preferably paired with zero maintenance – and guaranteed maximum availability. All of these objectives can be realized providing you are thoroughly familiar with your drive and care about its well-being. A few simple questions are enough to put yourself in the picture. How can you determine the condition of a drivetrain? Which loads are present and is there a risk of failure with certain load spectra? How can critical operating and load conditions be detected before it gets too late,

and what is the best way to reduce response times and align maintenance to condition and cost optimization aspects? torqXis, the intelligent sensor system for drive monitoring, provides answers to all these questions – in more and more applications.

### **Identify, measure and eliminate loads**

Torques, lateral forces and temperature – these three process-relevant variables in drivetrains are measured by the torqXis sensor system. The sensors in the torqXis series can be mounted easily as a measuring ring between the drive component and the machine bed. They are rated for nominal torques from 50 Nm to 3000 Nm and nominal lateral forces from 800 N to 30,000 N. The deformation of the sensor ring is determined whenever a load occurs in the drivetrain, e.g. in case of unexpected changes in the load profile, if defined values for measured mechanical quantities are exceeded or due to overheating, bearing damage, material breakage, slip, input shaft fatigue or a reduction in the drive belt tension. If a critical condition develops in the drivetrain or critical load spectra occur, the sensor immediately generates an alarm



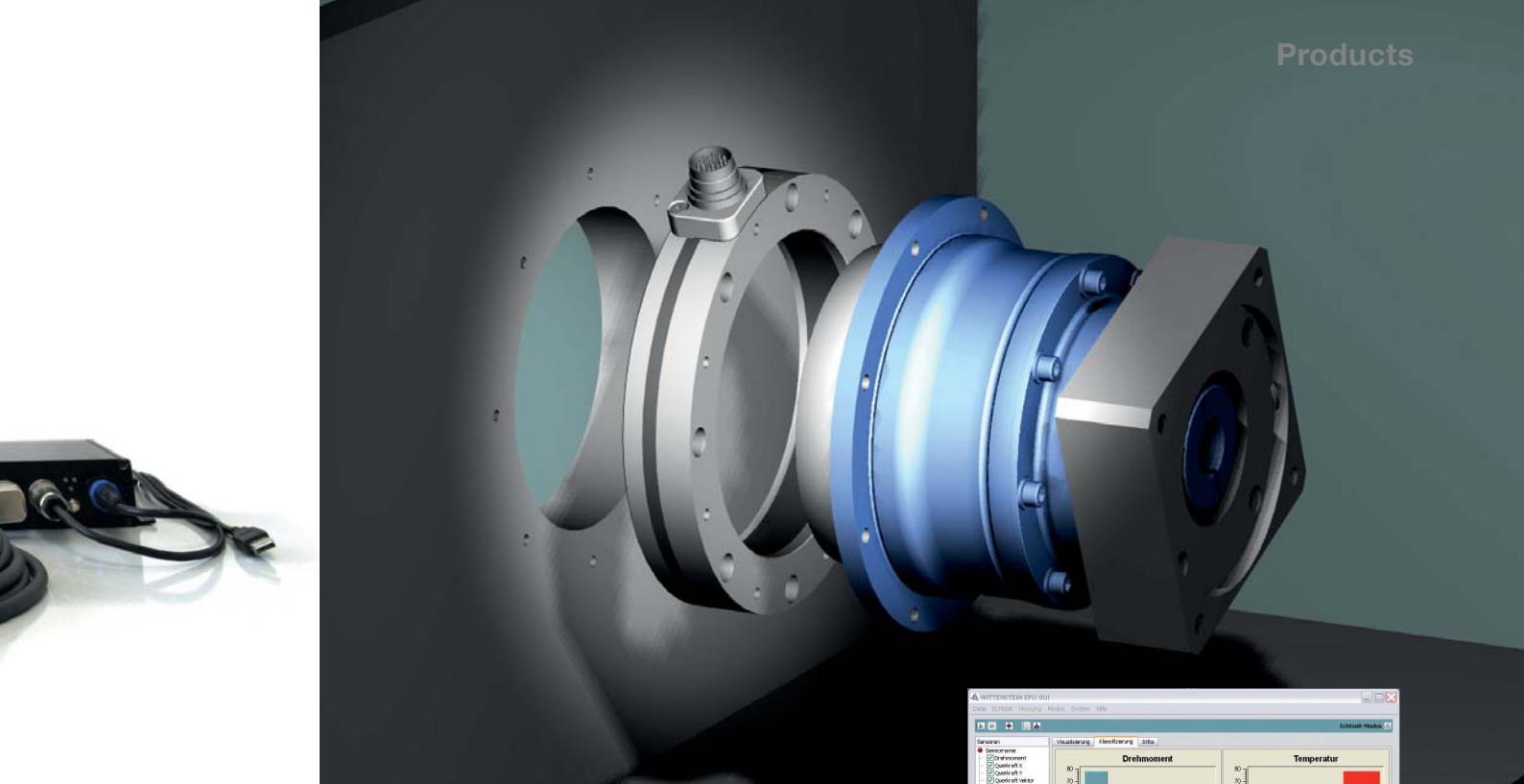

Unique design: the sensor system can be mounted easily as a measuring ring between the drive and the machine bed

Life cycle histogram of the measured values

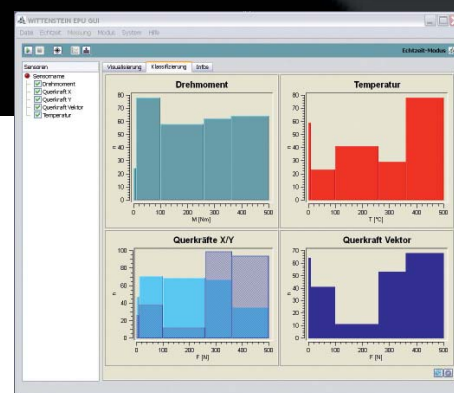

signal that is transmitted to the controller. The load can then be reduced or the motor switched off if necessary in order to prevent serious damage. At the same time, the information supplied by the sensor allows service assignments to be carried out in a targeted way and service intervals aligned to actual requirements, in other words made pro-cyclical and condition oriented.

#### Built-in “money back” guarantee

The combination of torque, lateral load and temperature measurements with torqXis results in smart concepts for condition monitoring and repair on demand. Economic assessments have confirmed that users of this innovative drive monitoring technology receive a kind of “money back” guarantee – because it effectively eliminates the costs for downtimes that are inevitable with unscheduled maintenance. This is aptly illustrated by a simple example of a customer in Switzerland. A machine that processes 340 parts with a value of four Swiss francs (CHF) in one hour had to be shut down twice unexpectedly in 2010 owing to bearing damage and an undetected reduction in the drive belt tension. The response

time until the machine was ready to start up again was around seven hours in each case. These fourteen hours translated into lost sales equivalent to approximately CHF 20,000.

To prevent this situation from reoccurring in future, the manufacturer decided to monitor the drivetrain concerned with a torqXis sensor. The outlay for the initial purchase, commissioning and integration into the control system amounted to a one-off figure of CHF 10,000. The investment in the sensor was consequently recovered in approximately six months. Moreover, the cost saving in the first year alone worked out at CHF 10,000. Added to this, the sensor promises to deliver sizeable financial benefits in the next few years because the risk of unscheduled downtimes has been virtually eliminated due to the early detection of wear and critical load spectra. A little torqXis intelligence in the drive train can certainly do no harm – and it could improve both the availability of your equipment and your return on investment significantly...

## Sophistication in engineering and design: RPM<sup>+</sup> motor-gearhead unit for innovative rack-and-pinion solutions



By Siegfried Wallauer  
Product Manager Rotary Actuator Systems at  
WITTENSTEIN motion control



**High-tech in an elegant yet functional style, convincing performance characteristics for linear technology, engineering ideas that add real value – these are the hallmarks of the new RPM<sup>+</sup> motor-gearhead unit in its role as an actuator for the High Performance Linear System.**

### Servo motor integration as a logical step

Back at the start of the year, the RP<sup>+</sup> was introduced at trade fairs and press conferences as a rack-and-pinion gearhead to facilitate linear drive solutions at the high end of the market. From the “technical” point of view, it represents the input stage of the new RPM<sup>+</sup> actuator. In terms of applications, it seamlessly unites all the familiar advantages such as a compact, elegant design, improved tilting moments for more tilting and system rigidity as well as increased positioning accuracy and exceptional ease of assembly thanks to the alpheno<sup>®</sup> interface. It is typical of WITTENSTEIN that the RPM<sup>+</sup> is far more than simply a gearhead with a servo motor mounted to it. The new actuator shows how traditional drive engineering limits can be pushed back when system expertise in gearhead manufacturing, gearing technology and the design of motor-gearhead combinations is consolidated under one roof and condensed in a single product.

### Length savings through intelligent integration

There is probably no other actuator solution for rack-and-pinion applications that packs such top-quality engineering into such a high-quality design as the RPM<sup>+</sup>. The integration of the permanently excited servo motor is only one benefit. The motor shaft is inserted directly into the gearhead, in other words the pinion is an integral element of the motor shaft with no intervening parts. This mechanical integration reduces the overall length. The fact that the brake is now accommodated in the cavity underneath the winding head rather than at the back of the motor is a second convincing example. All in all, the RPM<sup>+</sup> is 30% to 50% shorter than rival actuators boasting similar performance. The extremely rigid controlled system – and therefore optimal power transmission – of the actuator concept is a further advantage. Since the bearings are likewise designed for high radial forces, the RPM<sup>+</sup> is often built a size smaller than the industry standard – absolutely in line with the current trend towards downsizing.

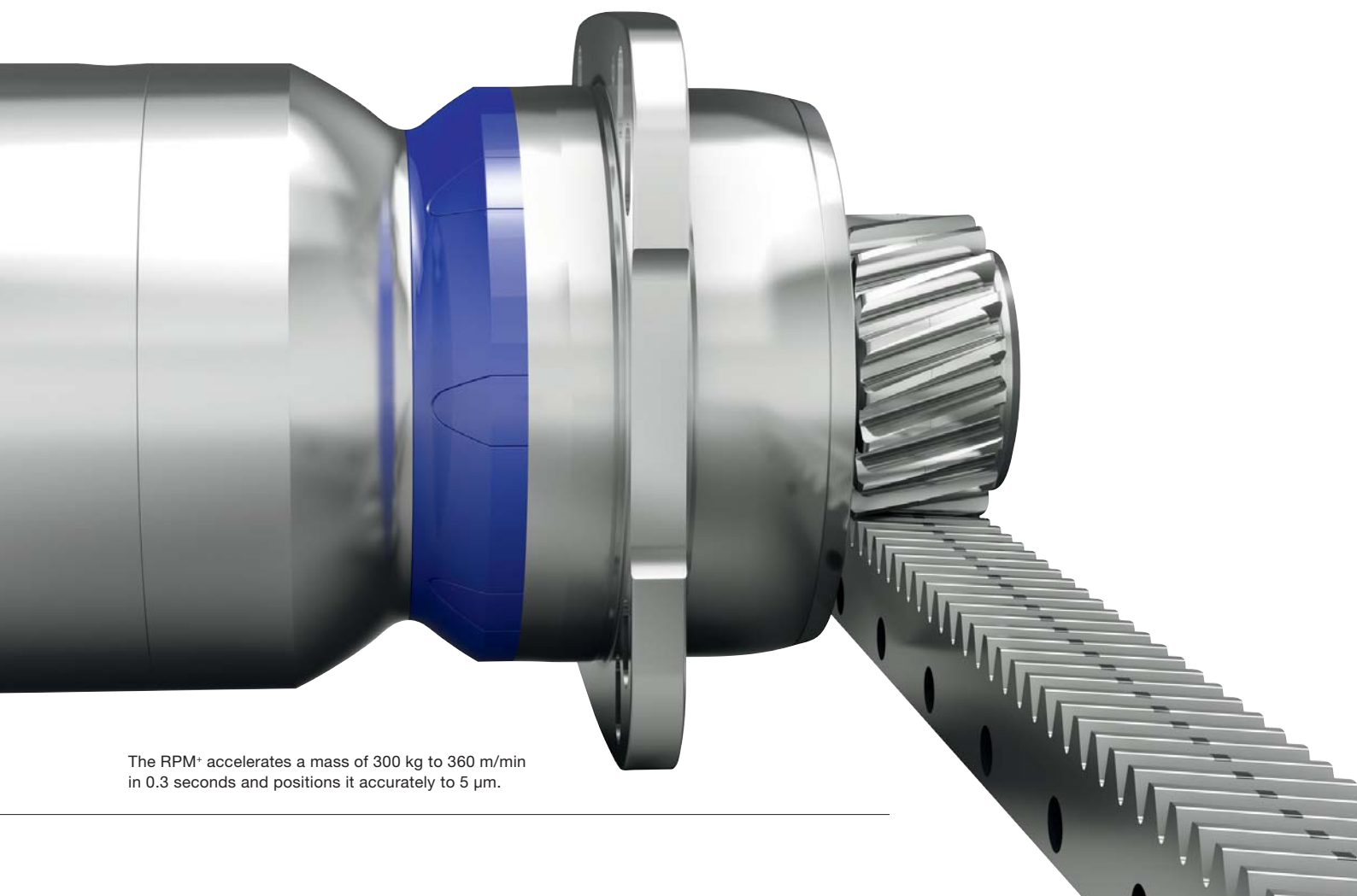

The RPM+ accelerates a mass of 300 kg to 360 m/min in 0.3 seconds and positions it accurately to 5 µm.

#### **RPM+: an eye-catcher with genuine added value**

Functionality and elegance are not necessarily a contradiction in terms – on the contrary, as WITTENSTEIN's experience in the last few years with its TPM+ actuators and other products confirms. This claim is equally valid for the RPM+. In the trade fair model or a customer machine – the design and colour of the housing transform the actuator into a real eye-catcher with high recognition value. What is pleasing to the eye is even more pleasing to the user because the design concept focuses systematically on providing additional functionalities and hence added value for the application. The smooth, rounded surface without any edges – and embellished with a two-component metallic coating – prevents dirt deposits from forming on the actuator. The pinion has a stylish cap featuring the WITTENSTEIN logo which not only protects against dirt but also looks good and conveys the same impression of top quality engineering as the seal that covers the transition to the gearhead. The mechanical interface with eight slotted holes

permits optimal adjustment of the pinion and rack – with no need for a separate adjustment plate that would cost money and detract from the visual message.

#### **Optimized for linear applications, open to customer requirements**

The High Performance Linear System with the RPM+ actuator integrates the motor, gearhead, pinion and rack in an optimally controllable system. It is available in four sizes with an air or water-cooled motor in several possible versions. WITTENSTEIN's cooperation with lead customers in multiple industries will determine which variants are manufactured in future and with which characteristics. Thanks to its high degree of flexibility and modularity, the RPM+ is excellently suited for almost any task in grinding, turning, portal milling, boring, laser, punching and pipe bending machines, water jet cutters, machining centres for wood-plastics compounds and basically any axes found in automation systems.



View inside the auditorium of the WITTENSTEIN academy

## Back to the classroom – to help you learn! Certified trainers train WITTENSTEIN customers

**WITTENSTEIN regularly places its own know-how at its customers' disposal in the framework of training courses and seminars – a service we take for granted and one that, thanks to a convincing, new train-the-trainer concept, will be distinguished by even greater excellence in future. For the first time, our trainers have undergone specific training at the WITTENSTEIN academy, to enable customers to profit even more from the technical expertise and vast experience of our engineering and product specialists.**

Providing high-quality training – tailored to the needs of each individual customer – is not so much a kind of mysterious talent as plain hard work. Trainers today are expected to have a wide range of competencies at their fingertips over and above their actual technical know-how. In a recent trainer certification seminar geared to practical needs, they learned how to design, prepare, deliver and follow up user training in a didactically sound way – both theoretically and in a series of role-playing exercises. The certified WITTENSTEIN trainers

are now better equipped than ever to empathize with different participant profiles and apply optimally adapted learning formats. The communication of complex technical content was explicitly addressed in a separate, compact module. The WITTENSTEIN academy was supported by its longstanding partner Claus Harten (Harten & Breuninger, Weikersheim/Baden-Württemberg), which designed and implemented the certification programme together with the personnel development department.

The official objective is to improve the quality of the training provided to WITTENSTEIN staff and customers and hence increase the long-term benefit for participants. The establishment of a network of trainers who advise and support each other is a welcome knock-on effect of the systematic training concept.

A start has been made – and there are already plans to repeat the project: between December 2011 and March 2012 another twelve trainers will take part in the certification programme under the motto “train the trainer”!



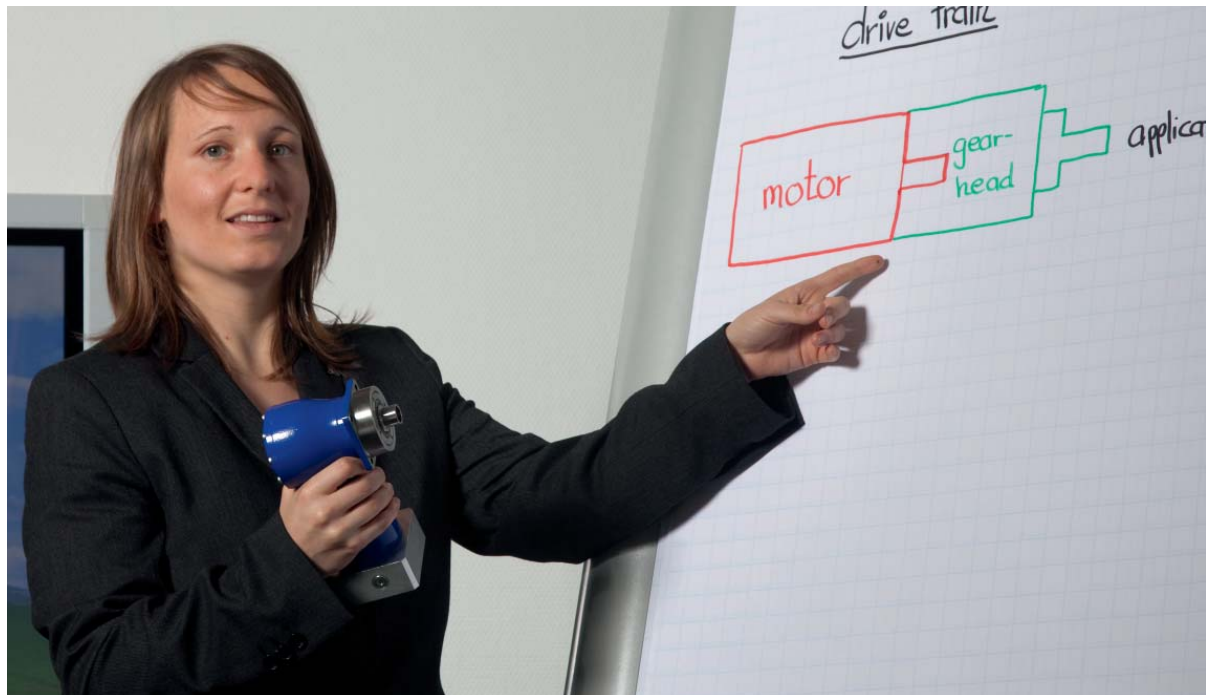

Marion Gakstatter is a certified WITTENSTEIN trainer

**Marion Gakstatter, Bachelor of Business Engineering and WITTENSTEIN trainer, took part in the first “train-the-trainer certification” seminar. In an interview with move, she reports on her experience:**

**move:** Which training do you provide to external customers?

**Marion Gakstatter:** I provide training in our cymex® sizing software as well as on products in the WITTENSTEIN alpha portfolio together with our Product Management.

**move:** Could you describe a few of the key challenges involved in customer training?

**Marion Gakstatter:** No two customer seminars are ever the same. For this reason, it is vital to clarify exactly what the client is seeking upfront and design the training to meet these individual needs. The train-the-trainer certification programme taught us what to watch out for here and helped us consolidate what we already knew. We will be better able to consider specific interests and wishes in future as a result.

**move:** You also work as an international trainer on behalf of WITTENSTEIN alpha. Where do the potential traps lie there?

**Marion Gakstatter:** I come into contact with a variety of personalities and learner types. As a trainer, I must do justice to

every single participant and take account of intercultural backgrounds where necessary. The qualification programme has showed me how to adapt my content more accurately to specific target groups and individual trainees.

**move:** WITTENSTEIN markets highly complex mechatronic drive systems. How do you communicate such complicated content without totally confusing the trainees?

**Marion Gakstatter:** By imparting my technical knowledge with the help of clearly structured, easy-to-understand product models and drawings that are based on real situations, for instance. By resorting to multimedia, I can make a seminar more exciting and more instructive, in line with the “see – touch – try out” principle. That’s one of the many skills a trainer has to master – which is why it was on the agenda at the qualification seminar.

**move:** Who should our customers turn to if they would like you to bring them up to date with the latest developments in drive engineering?

**Marion Gakstatter:** Just get in touch with the WITTENSTEIN sales engineer responsible for your area. We’d be delighted to design a seminar concept based on your particular requirements and interests.

## Italian projects meet German reliability

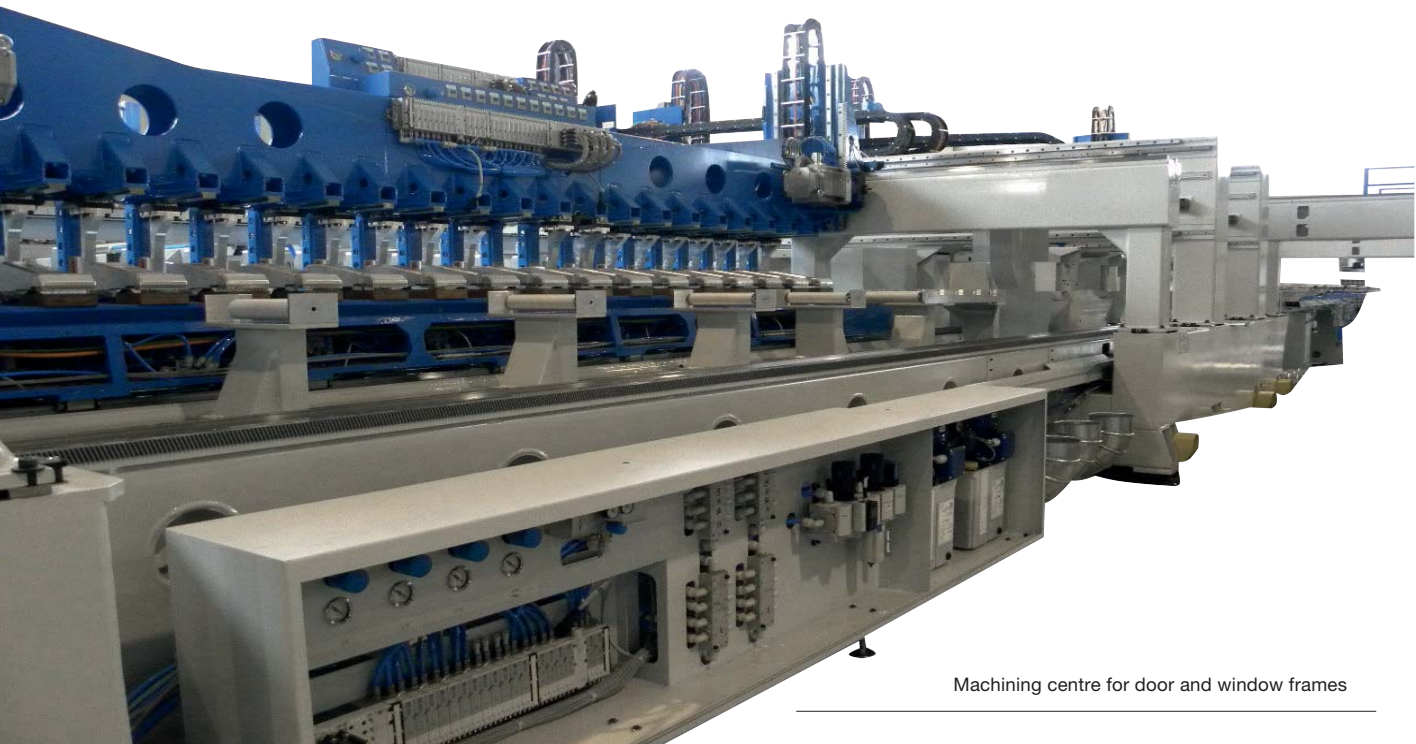

Machining centre for door and window frames

Images: Working Process

**“Working Process”, a company based in Settima di Gosolengo (Italy), specializes in planning and manufacturing machining centres for door and window frames. The machines it produces are capable of making up to a hundred windows a day with extreme precision – often as accurate as a tenth of a millimetre – in almost any shape and size, for example arched.**

High productivity, flexibility and reliability are the attributes on which the reputation of Working Process machines is founded – regardless of whether they are used in the manual trades or on highly automated industrial production lines. Stefano Schegginetti and Massimo Schiavetta, the firm’s two proprietors, have their roots in the manufacturing industry: “Innovation is an integral ingredient of our projects and patents that is invariably the outcome of specific user requirements. This is where our main strength lies.” Ever since Working Process’ establishment in the year 2000, its two founders have been keen to place the development of this strongly capitalized company on a firm footing, which is why they prefer to think in the long term. Working Process is a young enterprise operating in a mature market that is nevertheless creative

enough to come up with innovative production systems that are capable of surviving in the competitive global arena. A concept for prefinished, premilled, presquared and prepared door and window frames is currently being launched based on its systems. This process could prove to be the starting point for the most important modern revolution in the wood-frame production sector.

**“Sapiens”, “Antropos” and “Logos” – step one is always the innovation**

Working Process invests a substantial amount in sustainable research and development, often penetrating deep inside the company’s internal resources. “Working Process has a heavy export leaning – mainly within Europe – with a clear focus on high-tech advances and innovation. Our investments in products, technologies, marketing and R&D give us a clear lead in combination with dynamic entrepreneurship. We endeavour to capitalize on this advantage by selecting first-class suppliers like WITTENSTEIN”, says Schiavetta.

A large number of WITTENSTEIN systems are installed in Working Process machines. The two firms make a good match because they identify with similar values and attach

---

Vertical axis of the machining centre  
with the WITTENSTEIN alpha Linear  
System

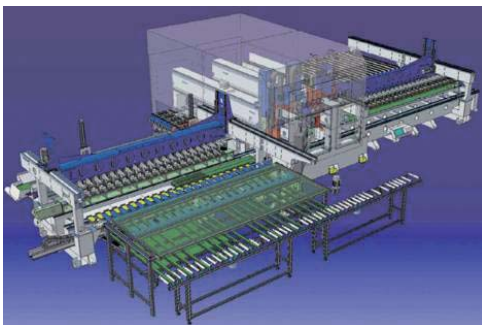
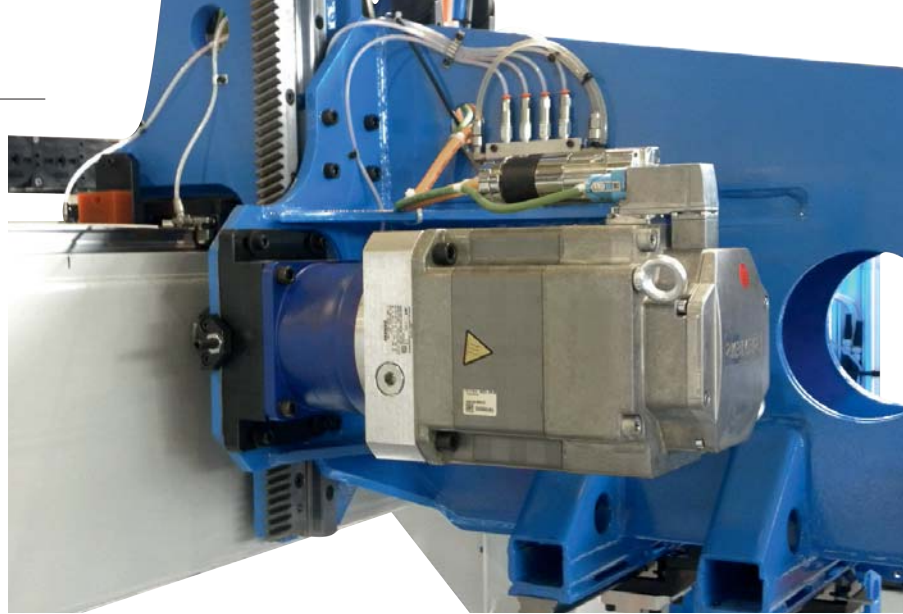

Typical Working Process machine

similar importance to excellence. “Sapiens”, “Antropos” and “Logos” – each of these three models has more than thirty axes that are moved by WITTENSTEIN gearheads, servo actuators and linear rack-and-pinion systems. Working Process chose these components because they guarantee precise motion, high acceleration, reliability, quiet running and significant energy savings.

#### Optimal solutions made by WITTENSTEIN

The products integrated in Working Process machines include highly precise planetary gearheads and servo actuators: the compact TP<sup>+</sup> planetary gearhead with output flange offers better power and torque transmission from the same footprint. The high torque version achieves an impressive 10,000 Nm. Thanks to its helical toothing and optimized components, the gearhead makes very little noise ( $\leq 58$  dB(A)) while the torsional backlash of  $\leq 1$  arcminute ensures unusually high positioning accuracy. “The SP<sup>+</sup> planetary gearhead, on the other hand, has a smooth, slotted or involute output shaft”, Schiavetta continues, “that guarantees high energy efficiency, as it can also be designed smaller owing to the high power density”. The new series has up to 25% higher torque

values than its predecessor and is characterized by exceptionally quiet running, high positioning accuracy and absolute reliability. The reduction ratios vary from  $i = 3$  to  $i = 100$ , with acceleration torques up to 4500 Nm and input speeds up to 6000 rpm.

The TPM<sup>+</sup> servo actuators, which are ideal for both rotary and linear applications, are another successful solution. They feature a compact design that makes them less sensitive to dirt. This product range comprises the highly dynamic and quiet-running TPM<sup>+</sup> dynamic, the TPM<sup>+</sup> power with high torques condensed into a tiny space and the compact TPM<sup>+</sup> high torque, which unites extremely high torsional rigidity with torques up to 10,000 Nm. The TPM<sup>+</sup> servo actuators are especially suitable for polar axes on tool heads or additional axes as well as for magazine axes used for tool changing. Finally, the “made-to-measure” alphen<sup>®</sup> planetary gearhead, which is explicitly configured for the individual requirements of each application, is likewise found in Working Process machines.

In short, WITTENSTEIN supplies the optimal solution for any axis.



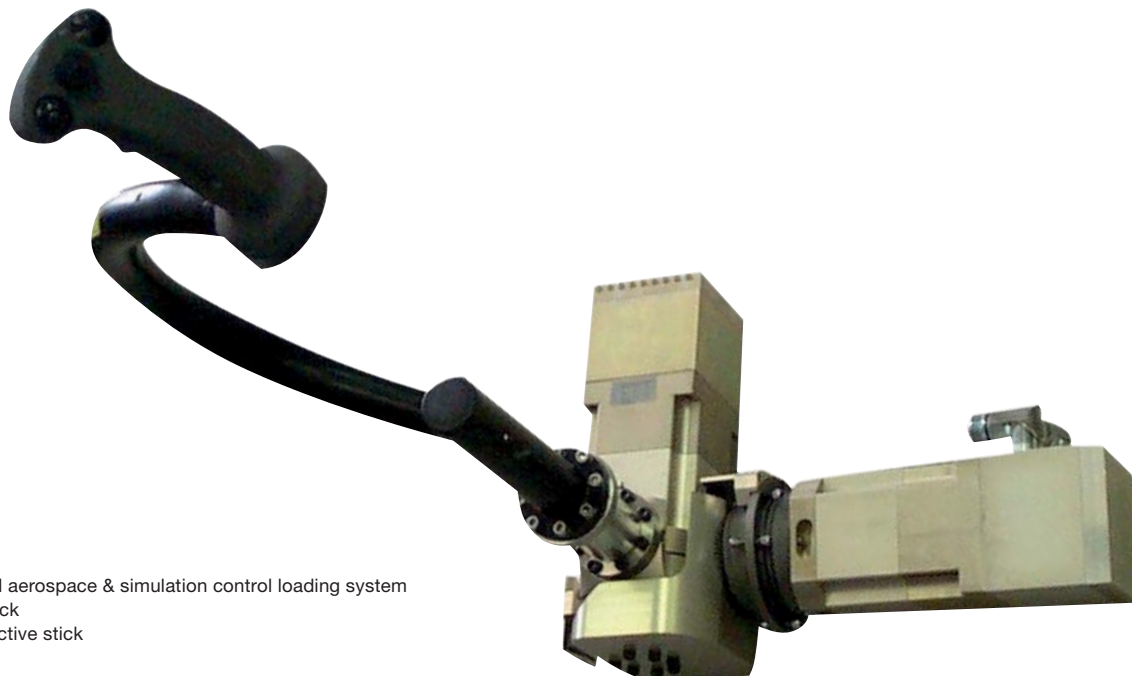

WITTENSTEIN aerospace & simulation control loading system  
Top: Cyclic stick  
Bottom: Collective stick

## Haptic technology for flight training

Researching and creating technology that positively impacts our environment takes more than drive and determination. It relies heavily on engineering expertise and collaboration, from the genesis of an idea to its realization for the greater good. WITTENSTEIN aerospace & simulation recognizes the hard work involved in cutting-edge technology and was inspired by the team at Deakin University when they started discussing their latest research project – the Universal Motion Simulator.

Deakin University's Centre for Intelligent Systems Research (CISR), based in Geelong (Australia), focuses on developing and analyzing state-of-the-art algorithms and methodologies that provide practical solutions to real-world problems. The Universal Motion Simulator (UMS) is one of the latest research projects from the team at CISR and uses WITTENSTEIN's control loading systems (CLS) to replicate helicopter control. This CLS includes a cyclic stick, a collective stick and directional pedals. CISR's UMS is a haptically enabled, full motion simulator for flight and vehicle training and performance analysis which uses customized control algorithms. Providing a realistic training environment, the simulator introduces a flexible, modular, high-fidelity motion system that can represent a variety of immersive training scenarios.

"The goal of this project is to gain a better understanding of vehicle and aircraft design and operator control. Research into user control with open and closed-loop scenarios will influence strategies aimed at improving performance and reducing the risk of accidents in vehicles and flights", says Prof. Saeid Navaei,

Director of the Centre for Systems. "This project is another opportunity for CISR to discover and deliver research that directly benefits society through the provision of solutions to real-world problems." Additional support in the process for the project came from the Australian Department of Defence, the Australian Research Council and Rockwell Collins.

Intelligent Research is another opportunity to discover and deliver research that directly benefits society through the provision of solutions to real-world problems." Additional support in the process for the project came from the Australian Department of Defence, the Australian Research Council and Rockwell Collins. WITTENSTEIN aerospace & simulation contributed the rotary wing control loading simulator system. This haptic control loading system enhances the training experience while the UMS is in closed-loop control. Integrated into the design, the cyclic stick, collective stick and directional pedals allow the simulator user to feel completely immersed in the real-world training environment.

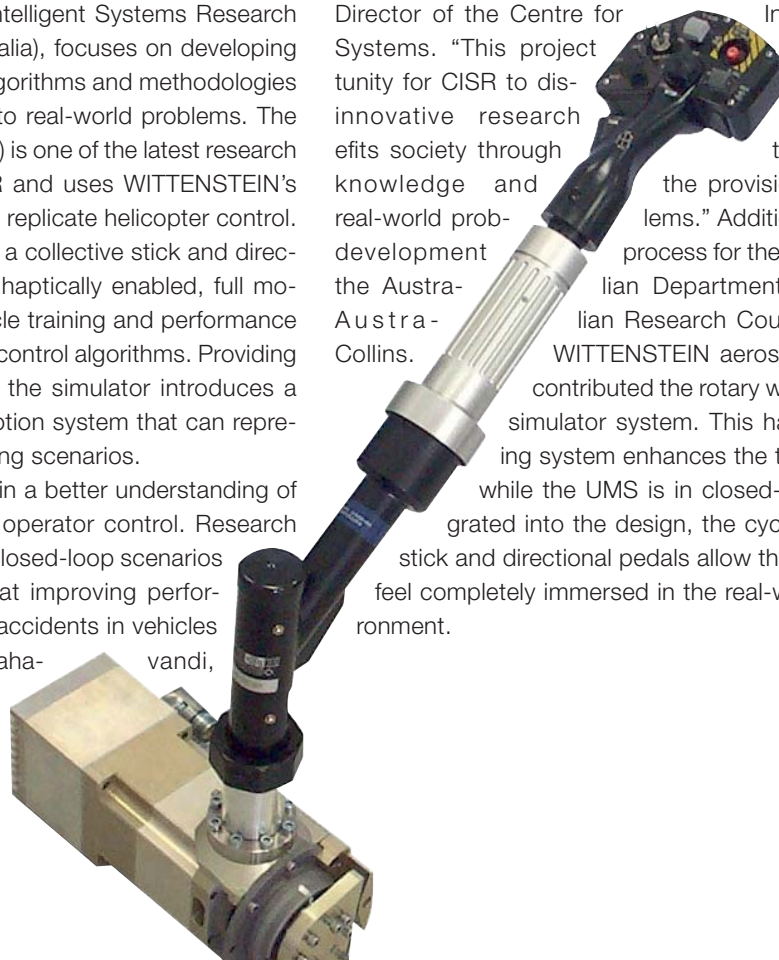



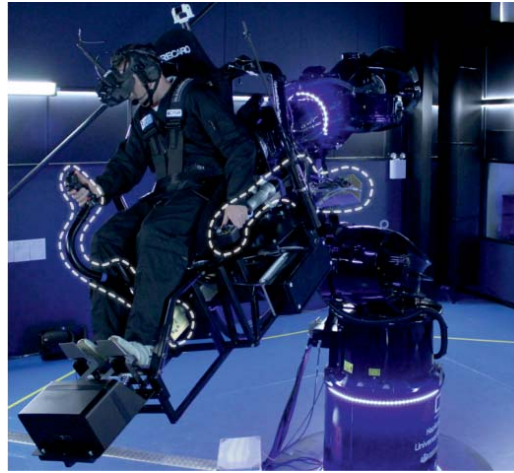

The Universal Motion Simulator is a state-of-the-art platform for training and performance analysis. With its special kinematic interface, two axes of continuous rotation are permitted, providing realistic g-force acceleration.

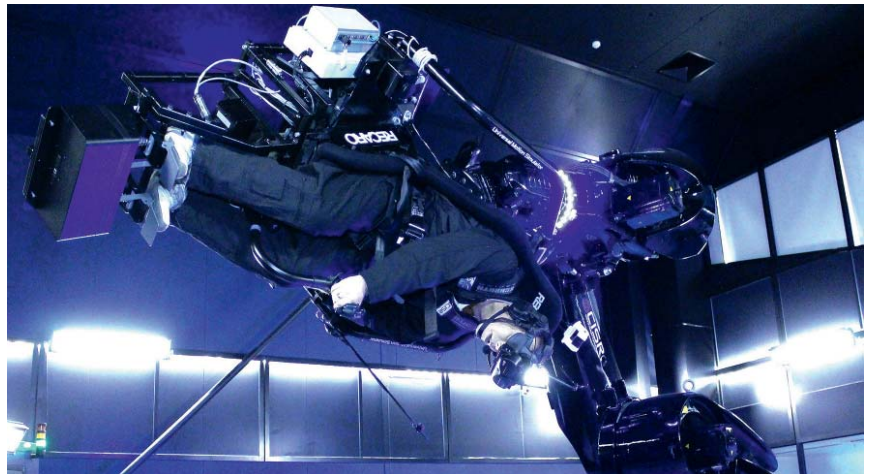

The simulator is intended to be used in two modes: open-loop control and closed-loop control. When in open-loop control mode, the user is automatically flown through predefined paths and sequences, from beginner through to expert training modules. During closed-loop control, the trainee has full control of the rotary wing aircraft via the active technology systems provided by WITTENSTEIN.

“The cyclic stick, collective stick and directional pedals utilized in the Universal Motion Simulator represent excellence in engineering, showing the synergy of the core WITTENSTEIN elements of mechanical, motor, electrical and software technology”, Scott Metcalfe, General Manager of WITTENSTEIN aerospace & simulation, Inc., continues.

This system is a perfect component for the UMS because it possesses the key performance and aesthetic characteristics that align with the objectives of the simulator: reconfigurable, compact and haptically enabled. WITTENSTEIN's active

technology utilizes a unique control scheme which communicates the force realism to the operator. The feedback via the control loading system provides the user with full sensory involvement. Making the rotary wing flight conditions as realistic as possible benefits CISR with the most valuable data for analyzing training results.

Taking today's technology and applying it to research that will positively impact the future shows the kind of engineering collaboration in which WITTENSTEIN will also participate in the coming years!

# POWER-IQ-Drives – compact and modular

## Compact motion control in mobile applications



By  
Peter Schuster  
Sales Manager at WITTENSTEIN electronics GmbH

POWER-IQ-Drives 250

The new POWER-IQ-Drives of WITTENSTEIN electronics are a complete series of compact and intelligent controllers with very high power density. The liquid-cooled converters can be used to control 3-phase machines in mobile applications with a maximum DC supply voltage of 750 V and provide peak power of up to 250 kVA. The power electronics system can be operated at high temperatures (max. 105° C ambient).

This exceptionally compact controller, that is roughly equivalent to a 12 V car battery in size, permits speed and torque control of permanently excited synchronous motors.

Above the nominal rotating field frequency, the motors can also be operated in field weakening. The high PWM-frequency of 16 kHz guarantees precise control response and extreme dynamics, even for high-speed motors with high stator frequencies and low leakage inductance. It also facilitates reliable control of multi-pole motors. The hardware consists of a modular DC link, the power and driver modules and the signal electronics system that is responsible for the control loop, monitoring and safety functions. The feedback interface is designed to evaluate a resolver signal.

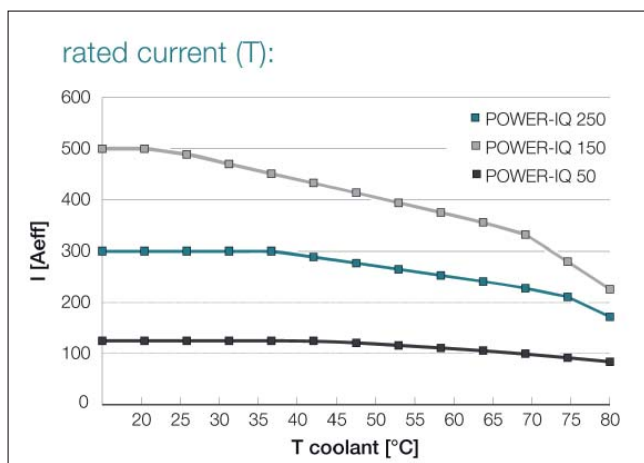

Output currents of power electronic systems as a function of the cooling water flow temperature

### Intelligent safety concept

Aided by a very powerful dual processor system, the intelligent electronics monitor the following parameters, amongst others:

- High battery voltage
- Overcurrent on the motor
- Short-circuit at the motor terminals
- Earth fault
- Position, motor current and temperature sensors
- Temperature measurements in the motor and output stage
- CAN errors
- Memory errors

The response to these monitoring functions can be adapted to take account of actual conditions and safety requirements.

Overview of available series:

| Power class                           | POWER-IQ 50                                       | POWER-IQ 150                        | POWER-IQ 250                        |
|---------------------------------------|---|-------------------------------------|-------------------------------------|
| Version                               | 50 kVA  | 150 kVA                             | 250 kVA                             |
| Nominal continuous power at $U_{NMS}$ | 50 kVA @ 300 V <sub>DC</sub>                      | 150 kVA @ 300 V <sub>DC</sub>       | 250 kVA @ 750 V <sub>DC</sub>       |
| Max. supply voltage                   | 300 V <sub>DC</sub>                               | 300 V <sub>DC</sub>                 | 750 V <sub>DC</sub>                 |
| Auxiliary supply voltage              | 420 V <sub>DC</sub>                               | 420 V <sub>DC</sub>                 | 900 V <sub>DC</sub>                 |
| Rated output current                  |   | 8...15 V <sub>DC</sub>              |                                     |
| Ausgangsbemessungsstrom               | 100 A <sub>NMS</sub>                              | 400 A <sub>NMS</sub>                | 250 A <sub>NMS</sub>                |
| Max. output current (10 s)            | 120 A <sub>NMS</sub>                              | 500 A <sub>NMS</sub>                | 300 A <sub>NMS</sub>                |
| PWM frequency                         |   | 16 kHz                              |                                     |
| Controller frequency                  |   | 16 kHz                              |                                     |
| Communication                         |   | CAN                                 |                                     |
| Operating mode                        | Speed / torque control with sine wave commutation |                                     |                                     |
| Feedback encoder                      |   | Resolver                            |                                     |
| Cooling system                        | Liquid cooler, 50/50 water-glycol                 |                                     |                                     |
| Dimensions                            | W: 170 mm<br>H: 120 mm<br>D: 170 mm               | W: 220 mm<br>H: 200 mm<br>D: 220 mm | W: 220 mm<br>H: 200 mm<br>D: 220 mm |
| Weight                                | ~7 kg   | ~9 kg                               | ~10 kg                              |
| Degree of protection                  |   | IP65                                |                                     |

Basic technical data of the converter family

**POWER-IQ-Drives – powerful and flexible**

The various POWER-IQ-Drives series add up to a modular controller concept that is characterized by very high integration density as well as maximum flexibility and scalability.

**POWER-IQ-Drives – customized solutions**

The consistent application of a modular design principle generates crucial advantages for our customers. From the initial drive concept through the development process to the trial run, we take pleasure in supporting you with our extensive expert know-how.

For more information, please contact Peter Schuster, Sales Manager at WITTENSTEIN electronics GmbH, e-mail: [peter.schuster@wittenstein.de](mailto:peter.schuster@wittenstein.de).

**TRADE FAIR CALENDAR 2011/12 (selection)**



**Motek 2011**, Stuttgart (Germany)  
International Trade Fair for  
Assembly and Handling Technology  
WITTENSTEIN alpha GmbH,  
WITTENSTEIN motion control GmbH,  
WITTENSTEIN cyber motor GmbH  
Hall 9, Stand 9121  
**October 10 to 13, 2011**



**Forum Maschinenbau**, Bad Salzuffen  
(Germany)  
Trade Fair for Suppliers in the  
Machinery Manufacturing Industry  
WITTENSTEIN alpha GmbH  
Hall 20, Stand A57  
**November 9 to 11, 2011**



**SPS/IPC/DRIVES 2011**, Nuremberg (Germany)  
Exhibition for Electric Automation –  
Systems & Components  
WITTENSTEIN alpha GmbH,  
WITTENSTEIN motion control GmbH,  
WITTENSTEIN cyber motor GmbH,  
WITTENSTEIN electronics GmbH  
Hall 4, Stand 221  
**November 22 to 24, 2011**



**Hanover Fair 2012**, Hanover (Germany)  
Industrial Automation  
WITTENSTEIN Group  
**April 23 to 27, 2012**



**HISPACK 2012**, Barcelona (Spain)  
International Packaging Exhibition  
WITTENSTEIN S.L.U.  
**May 15 to 18, 2012**



**BIEMH 2012**, Bilbao (Spain)  
International Machine Tool Biennial  
WITTENSTEIN S.L.U.  
**May 28 to June 2, 2012**



**Metalloobrabotka 2012**, Moscow (Russia)  
13th International Exhibition for Materials  
Processing  
Technologies, Machines and Tools  
WITTENSTEIN alpha GmbH  
**May 28 to June 1, 2012**



**Eurosatoy 2012**, Paris (France)  
International Exhibition for Land and  
Land-Air Defence  
WITTENSTEIN motion control GmbH,  
Special Applications Business Division  
**June 11 to 15, 2012**



